



Robotic Assembly

Multiple Part Handling Actuator ML308793

BENEFITS

- Each finger pad supports a gripping device
- Used to pick an array of parts and opens for ease of assembly
- Increased production throughput
- Ideal for automotive assembly and placement of fasteners
- Jaws can be individually adjusted to eliminate backlash
- Other jaw configurations available, consult PHD Unlimited Unique Solutions®



Closed position

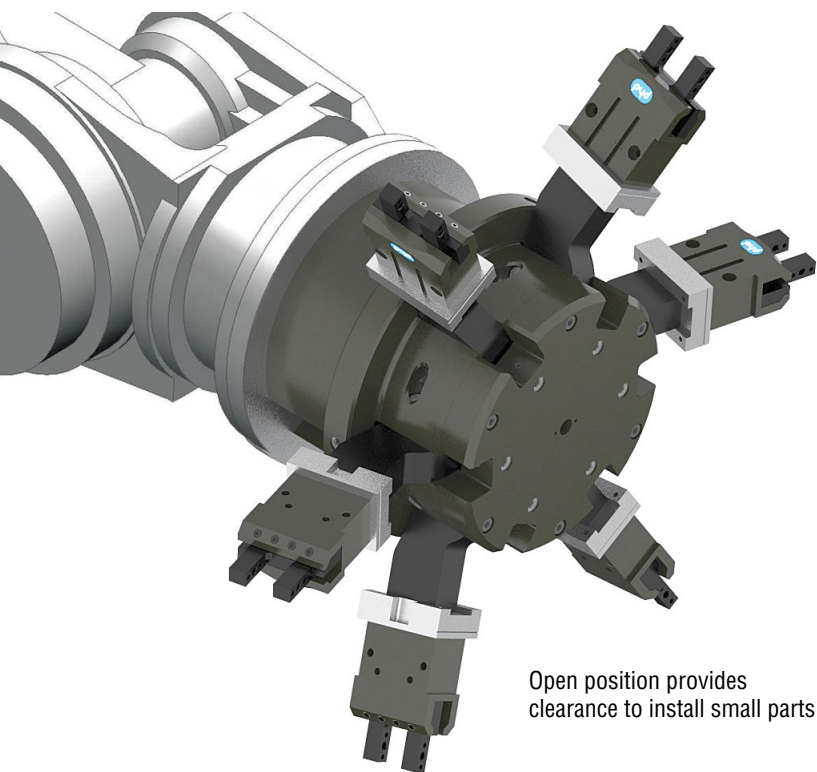

Open position provides clearance to install small parts



Open position

© Copyright 2019, by PHD, Inc. All Rights Reserved. Printed in the U.S.A.

8/19 10988

CP308793



PHD is a member of the
MAC Distributor Network



SOLUTIONS FOR INDUSTRIAL AUTOMATION

www.phdinc.com